



## THERMODYNAMIC PERFORMANCE ANALYSIS OF ALKHOMS STEAM TURBINE POWER PLANT

Muammer Alus\*, Fathi Kawan, Abdulla Ahmed

University of Elmergib, Faculty of Engineering-Alkhoms  
Mechanical and Industrial Engineering Department  
Alkhoms, Libya

### Abstract

The aim of this work was to studies of the thermodynamic performance of Alkhoms steam power plant, which was established in 1982. The study included the thermodynamic parameters analysis of design and operational cases at the time of this study, as well as making comparison between them. The thermodynamic parameters comprise the producing capacity (specific work) and the thermal efficiency of the steam power plant. A steam power plant of (120 MW) with a typical design of commercial steam power plant was demonstrated. The programming of the performance model for Alkhoms steam power plant was developed utilizing FORTRAN 90. The results of the study revealed that the thermal efficiency of the plant in the operational case decreased by 5.43 % compared to the design case. In addition, the feed water temperature in the operational case decreased by 74 °C .

**Keywords:** Power Plant, Steam Turbine, Thermodynamic, Thermal Efficiency.

**\*Corresponding author**

**E-Mail:** [alus31@yahoo.de](mailto:alus31@yahoo.de) (Dr. Muammer Alus)

### 1. INTRODUCTION

It is known that one of the most important sources of electrical energy production around the world is the steam power plants, so it was focused on by the energy research centers to improve thermodynamic variables. The main components of steam power plant are: the steam generator, the steam turbine, the condenser, the feed pump and the heaters. Mountings and accessories are also part of the plant to control its operation and to enhance the plant performance. The thermal efficiency of the steam power plant depends on each component condition, for instance; the condenser is considered one of the main components that affect the plant performance. A steam condenser is a piece of machinery that turns steam into water. Water is heated into steam, the steam provides motivation for a process, a steam condenser turns it back into water, and the cycle begins again [1].

Different approaches can be found in the literature regarding the performance of the steam power plants. (Hesham G. Ibrahim et al [2]) studied how to improve the performance of the steam power plant. The authors concluded that, results of simulation process of steam power plant done using (HYSYS v.3.2), led to increase the overall efficiency from 24.57% up to 28.1%, through prevent erosion occurs and to decrease heat loses by the condenser, also increasing the output rate of electrical power produced to about 15% . (Hesham G. Ibrahim et al [3]) examined a number of alternative designs to upgrade the existed Alkhoms steam power plant, in order to improve the thermal and overall efficiencies, which was achieved by HYSYS. The efficiency of Rankine cycle is improved by using an intermediate reheat cycle in a number of configurations. The results indicate that configuration No.3 offers the highest efficiency and less amount of energy



consumption than the other configurations which used in the study. (Muammer Alus et al [4]) performed a thermoeconomic optimization of steam condenser for combined cycle power plant. The authors found that the thermoeconomic optimization procedure led to a significant improvement for the thermodynamic parameters and economic parameters, where the thermal efficiency could be increased by about 0.37% , and the annual cash flow was increased by 1.1 M\$.

Since studies are not sufficiently available on Alkhoms steam power plant specifically, and also due to it is an old fashioned steam power plant which was established in 1982. These aspects have prompted this paper to focus on the study of the thermodynamic performance (specific work and thermal efficiency) of Alkhoms steam turbine power plant.

## 2. THERMODYNAMIC MODEL

### 2.1 Description of the model

The thermodynamic model provides a modular structure for the Alkhoms steam power plant as shown in Figure 1.

Alkhoms steam power plant consists of four Steam units. Each unit has a capacity of about 120 MW and consists of three stages, the high pressure steam turbine stage, the intermediate pressure steam turbine stage, and the low pressure steam turbine stage. The turbines which used in the plant are made by SIMENS, and they are of an impuls-reaciton turbine type. The steam generator (Boiler) is manufactured by Babcock. Each steam cycle of the Alkhoms steam plant contains six steam extraction lines: three high pressure heaters, two low pressure heaters, and also a feed water tank, which is an essential and important part for feeding the boiler of feed water through the feed water pump. Alkhoms steam plant includes a condenser of the surface area type in which the steam is converted into water. The water is pumped from the condenser via a condenser pump (CP) to the low pressure heaters (LPH). Also, the steam cycle in the plant contains an ejector, which is divided into a primary dehydrator and a main extractor. The plant generator (G) is installed on the same shaft of the turbines, where it converts mechanical energy into electrical energy [5].

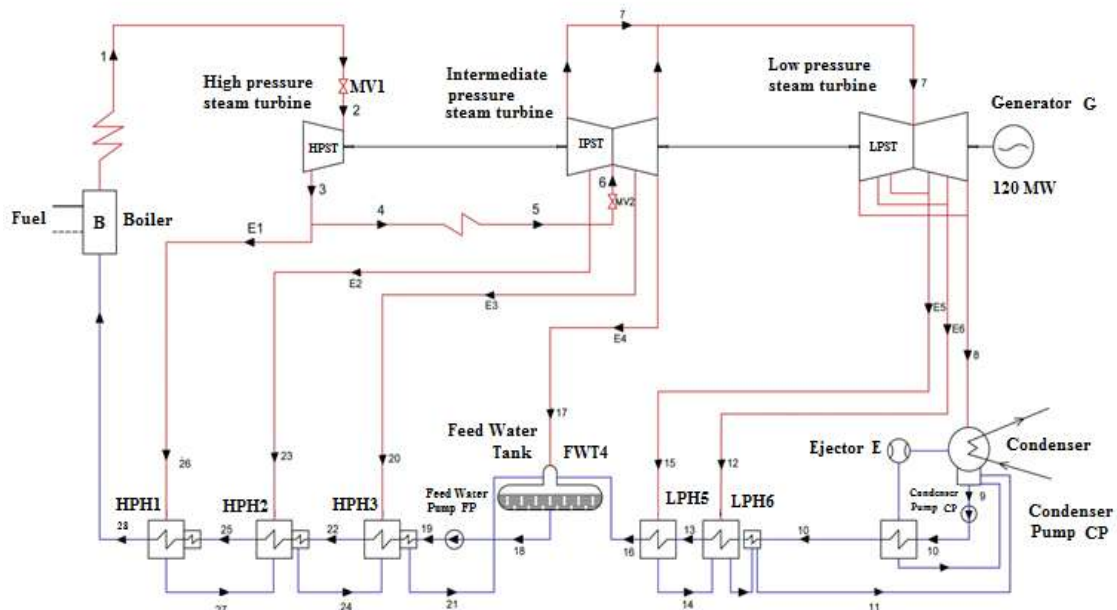

Fig. 1 A schematic diagram of Alkhoms steam power plant [4]



## 2.2 Technical Specifications of the model

The technical specifications data of a single unit for Alkhoms steam turbine power plant and assumptions which are used in

calculating of the thermodynamic parameters are presented in the Table 1.

**Table1: Technical specifications of Alkhoms steam power plant,(Design case)[5, 6]**

Parameter	Value
<b>1. SIEMNS / IMPULS-REACTION TURBINE</b>	
Electrical power at the generator output [MW]	120
Live steam pressure (HP) [bar]	130
Live steam temperature at the inlet of the HP steam turbine ( $t_{MV1}$ ) [°C]	353
Pressure of reheat steam (IP steam turbine) [bar]	30
Temperature of the reheat steam (IP steam turbine) ( $t_{MV2}$ ) [°C]	353
Steam pressure for the first extraction line ( $P_{E1}$ )	30
Steam pressure for the second extraction line ( $P_{E2}$ ) [bar]	18.23
Steam pressure for the third extraction line ( $P_{E3}$ ) [bar]	9.43
Steam pressure for the fourth extraction line (Feed water tank line) ( $P_{E4}$ ) [bar]	4.67
Steam pressure for the fifth extraction line ( $P_{E5}$ ) [bar]	2.15
Steam pressure for the sixth extraction line ( $P_{E6}$ ) [bar]	0.702
Low-pressure steam turbine outlet (condenser pressure) ( $P_{Cond}$ ) [bar]	0.0538
Feed water temperature [°C]	226.5
<b>2. Assumption</b>	
The isentropic efficiency of all three steam turbine parts [%]	90
The isentropic efficiencies of water pumps [%]	82
The mechanical efficiency [%]	99.5
The generator efficiency [%]	98



### 2.3 Calculation of thermodynamic parameters

The thermodynamic parameters of this study are the specific work and the thermal efficiency of the plant. The computer code to calculate the heat balance of the Alkhoms steam power plant was developed using FORTRAN 90. The water-steam properties were derived from the standard IAPWS-IF97 [7].

#### 2.3.1 Calculation of the unit steam extractions

After the thermodynamic properties of water-steam in all steam cycle points have been calculated. The unit steam extractions from the turbines of Alkhoms steam power plant can be determined by applying the energy balances for flow at each single heater. The energy balance equation for the high pressure heater1 (HPH1) gives

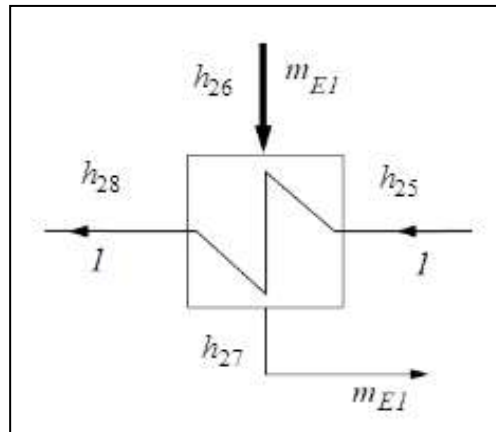

Figure 2 High pressure heater 1

$$m_{E1} (h_{26} - h_{27}) \cdot \eta_{HPH} = 1 \cdot (h_{28} - h_{25}) \quad (1)$$

$$m_{E1} = \frac{(h_{28} - h_{25})}{\eta_{HPH} \cdot (h_{26} - h_{27})} \quad (2)$$

where  $m_{E1}$  is the unit steam extraction of HPH1,  $h_{25}$  is the enthalpy of steam entering HPH1,  $h_{26}$  is the enthalpy of steam extraction 1 entering HPH1.  $h_{27}$  &  $h_{28}$  are the enthalpies of steam at the exit of HPH1.

The unit steam extraction of HPH2 and HPH3 ( $m_{E2}$  &  $m_{E3}$ ) are determined in a similar manner to HPH1 ( $m_{E1}$ ). Applying the energy balance equation for the feed water tank (FWT4) yields

$$[m_{E4} h_{17} + (m_{E1} + m_{E2} + m_{E3}) \cdot h_{21}] + \left(1 - \sum_1^4 m_{Ei}\right) \cdot h_{16} = 1 \cdot h_{18} \quad (3)$$

$$m_{E4} = \frac{h_{18} - h_{16}}{h_{17} - h_{16}} - (m_{E1} + m_{E2} + m_{E3}) \frac{(h_{16} - h_{21})}{(h_{17} - h_{16})} \quad (4)$$



where  $m_{E4}$  is the unit steam extraction of extraction 4 ( *FWT* ),  $h_{17}$  is the enthalpy of steam extraction 1 entering *FWT* .  $h_{16}$  &  $h_{21}$

are the enthalpies of steam entering *FWT* .  $h_{18}$  is the enthalpy of steam at the exit of *FWT* .

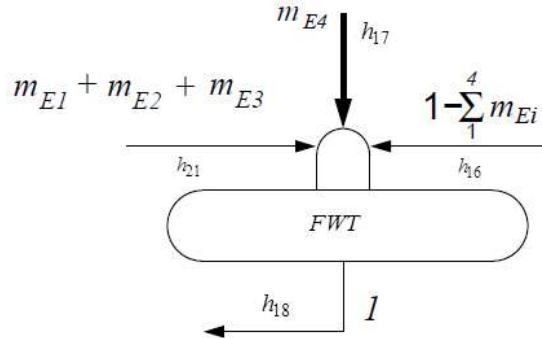

Figure 3 Feed water tank

The application of the energy balance equation for the low pressure heater 1 ( *LPH5* ) gives

$$m_{E5} (h_{15} - h_{14}) = \left( \sum_{i=1}^4 m_{Ei} \right) \cdot (h_{16} - h_{13}) \quad (5)$$

$$m_{E5} = \left( 1 - \sum_{i=1}^4 m_{Ei} \right) \cdot \frac{h_{16} - h_{13}}{h_{15} - h_{14}} \quad (6)$$

where  $m_{E5}$  is the unit steam extraction of extraction 5 ( *LPH5* ).  $h_{15}$  is the enthalpy of steam extraction 5 entering *LPH5* .  $h_{13}$  is the enthalpy of steam entering *LPH5* .

$h_{14}$  &  $h_{16}$  are the enthalpy of steam at the exit of *LPH5* .

At the same way one can calculate  $m_{E6}$  from a balance for low pressure heater 6 ( *LPH6* ).

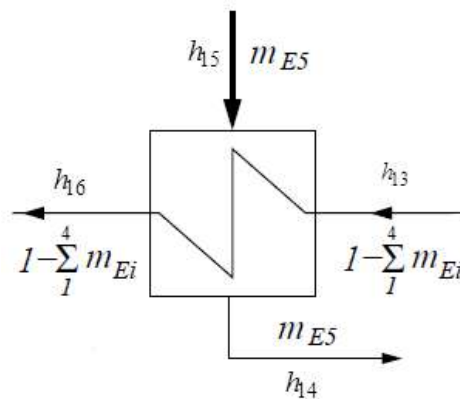

Figure 4 Low pressure heater 5 ( *LPH5* )



### 2.3.2 Calculation of thermodynamic parameters

Main thermodynamic parameters show the quality of the steam turbine and the whole thermal power plant regarding the transformation of thermal energy into the electrical energy [8].

The thermodynamic parameters are:

$$w_{ST} = \eta_m \cdot \eta_g \cdot \left\{ 1 \cdot \Delta h_1 + (1 - m_{E1}) \cdot \Delta h_2 + (1 - \sum_1^2 m_{Ei}) \cdot \Delta h_3 + (1 - \sum_1^3 m_{Ei}) \cdot \Delta h_4 + (1 - \sum_1^4 m_{Ei}) \cdot \Delta h_5 + (1 - \sum_1^5 m_{Ei}) \cdot \Delta h_6 + (1 - \sum_1^6 m_{Ei}) \cdot \Delta h_7 \right\} \quad (7)$$

where  $\Delta h_1, \Delta h_2, \Delta h_3, \Delta h_4, \Delta h_5, \Delta h_6$  and  $\Delta h_7$  are the enthalpy drops in HP, IP and LP

- Specific electrical generator work and
- Thermal efficiency of the steam power plant

The specific electrical generator work is defined as:

steam turbine part of Alkhoms steam turbine power plant as shown in figure 5.

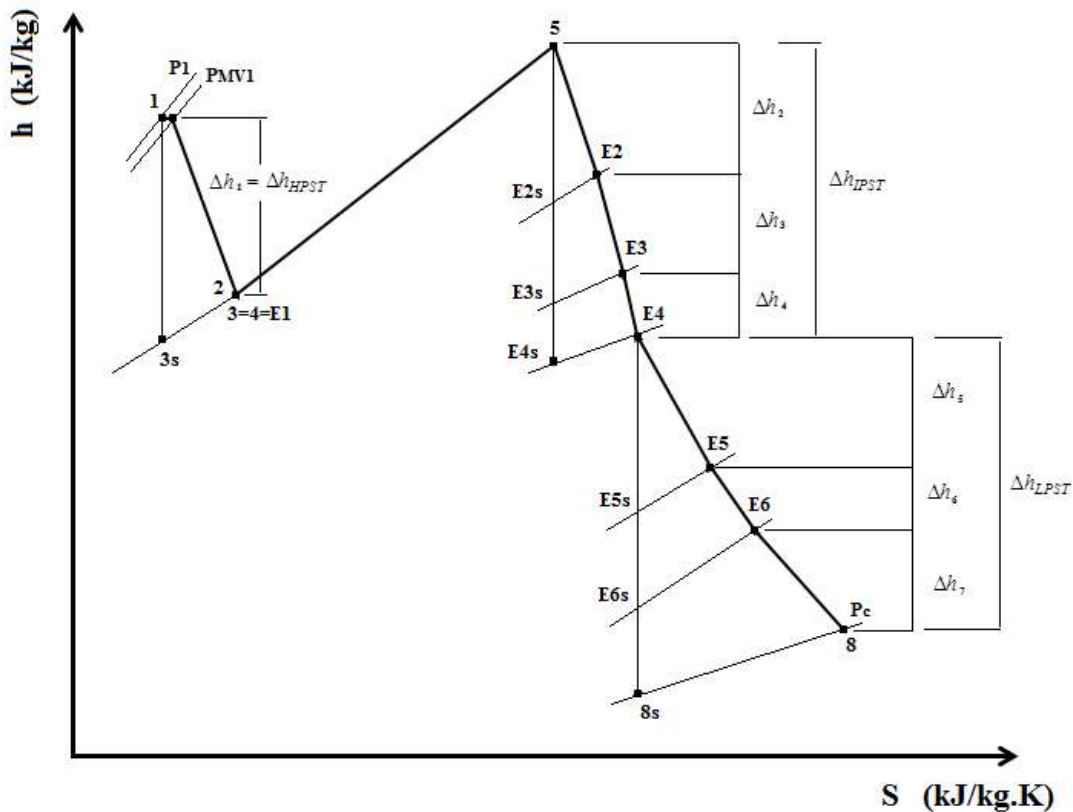

Figure 5 Steam expansion line in the turbine part of Alkhoms steam power plant



The mass flow rate through the main control valve 1 is:

$$\dot{m}_{ST} = \dot{m}_{MV1} = \frac{P_{ST}}{w_{st}} \quad (8)$$

where  $P_{ST}$  is the output power and  $w_{st}$  is the specific electrical work of the Alkhoms steam power plant.

$$\dot{m}_{MV2} = (1 - m_{E1}) \cdot \dot{m}_{ST} \quad (9)$$

$$\eta_{th} = \frac{P_{ST}}{Q_{add}} = \frac{P_{ST}}{\dot{m}_{MV1} \cdot (h_1 - h_{28}) + \dot{m}_{MV2} \cdot (h_5 - h_4)} \quad (11)$$

where  $Q_{add}$  is the heat added in the boiler.

### 3. THE OPERATIONAL CASE OF THE PLANT

The literature on energy analysis of the Alkhoms steam power plant reveals a lack of clear information under certain operating conditions. Therefore, the plant engineers were contacted and consulting to obtain operational data, and the following has been found:

- A decrease in the plant's power output from 120 MW to 95 MW
- An increase in condenser pressure from 0.0538 bar to 0.4 bar.

Calculation of the rate of steam flow passing through the extraction lines is defined as:

$$\dot{m}_{ST,Ei} = m_{Ei} \cdot \dot{m}_{ST} \quad (10)$$

where  $i$  is the number of the extraction line of the Alkhoms steam power plant.

The thermal efficiency of the whole Alkhoms steam power plant is defined by the following relation:

- Clogging in the condenser pipe from seaweed and sand.
- High pressure heaters ( $HPH1, HPH2$  &  $HPH3$ ) of the plant are out of duty.

Therefore, all these considerations were taken into account in calculating the thermodynamic parameters of the plant for the operational case. Table 2 shows the operational case data for the Alkhoms steam power plant.



**Table2: The operational case data for Alkhoms steam power plant.**

Parameter	Value
Electrical power at the generator output [MW]	95
Live steam pressure (HP) [bar]	130
Live steam temperature at the inlet of the HP steam turbine ( $t_{MV1}$ ) [°C]	353
Pressure of reheat steam (IP steam turbine) [bar]	30
Temperature of the reheat steam (IP steam turbine) ( $t_{MV2}$ ) [°C]	353
Steam pressure for the first extraction line ( $P_{E1}$ ) [bar]	-
Steam pressure for the second extraction line ( $P_{E2}$ ) [bar]	-
Steam pressure for the third extraction line ( $P_{E3}$ ) [bar]	-
Steam pressure for the fourth extraction line (Feed water tank line) ( $P_{E4}$ ) [bar]	4.67
Steam pressure for the fifth extraction line ( $P_{E5}$ ) [bar]	2.15
Steam pressure for the sixth extraction line ( $P_{E6}$ ) [bar]	0.702
Low-pressure steam turbine outlet (condenser pressure) ( $P_C$ ) [bar]	0.4

#### 4. RESULTS AND DISCUSSION

The thermodynamic parameters represented in the specific work and the thermal efficiency were calculated for both cases, the design case and the operational case of the Alkhoms steam power plant, as well as studying the effects of the live steam pressure and the condenser pressure on those thermodynamic parameters.

Figure 5 shows the Effect of live steam pressure ( $p_{st, live}$ ) variations on the

thermodynamic parameters (specific work  $w_{ST}$  and thermal efficiency  $\eta_{ST}$ ).

It can be noticed from figure 5 that the power plant specific work and thermal efficiency increase with an increase in live steam pressure. As the live steam pressure continues to increase, the specific work of plant increases quickly, so the result is an increase in the power output of the plant.

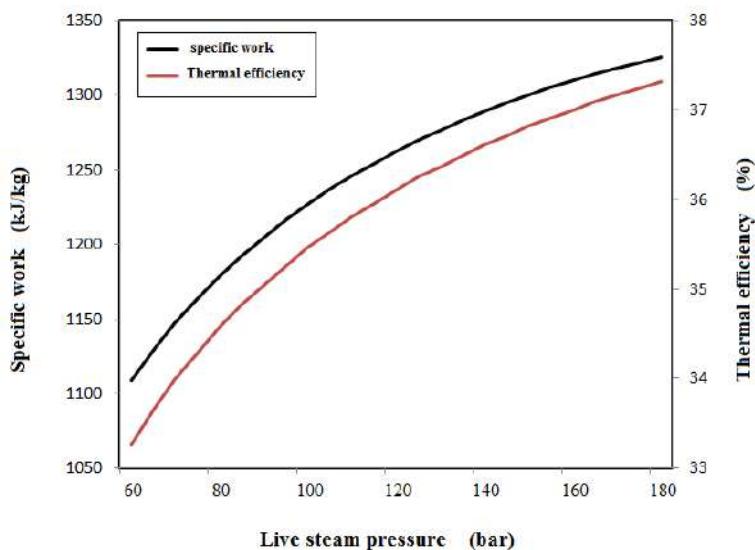

Figure 5 The Effect of live steam pressure variation on the thermodynamic parameters

Figure 6 shows the thermodynamic parameters ( $w_{ST}$  &  $\eta_{ST}$ ) as a function of condenser pressure ( $p_{Cond.}$ ) of Alkhoms steam power plant. The results show that the  $w_{ST}$  &  $\eta_{ST}$  decrease with increasing the  $p_{Cond.}$ .

Decreasing the  $p_{Cond.}$  will lead to a higher power output ( $P_{ST}$ ) of the power plant for the same mass flow rate ( $\dot{m}_{ST}$ ) and fuel input ( $\dot{m}_f$ ) into steam generation (Boiler).

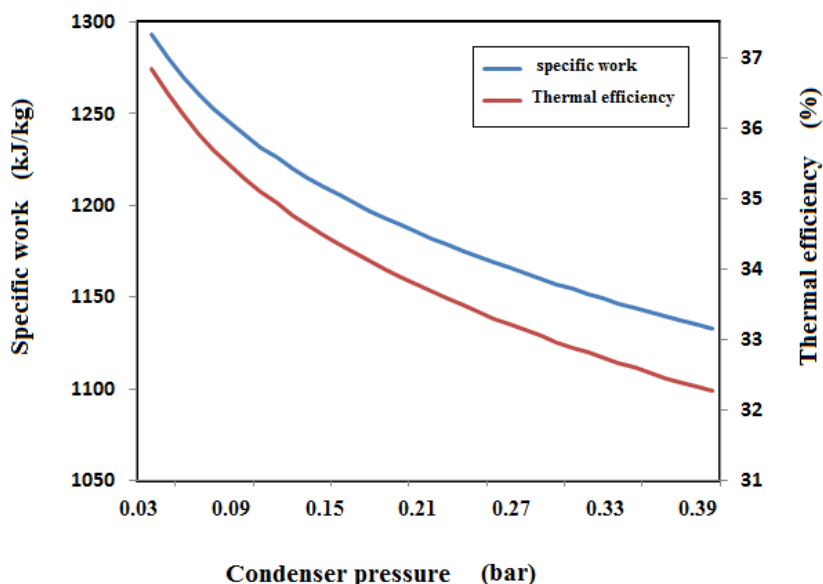

Figure 6 Effect of condenser pressure variations on the thermodynamic parameters



It can be seen from the table 3, that the steam flow rate for the low pressure heater 6 (*LPH6*)  $\dot{m}_{ST,E6}$  decreases in the operational case compared with the design case by an obvious difference from 8.96 kg/s to 1.47 kg/s, and that due to the increase in condenser pressure in the operational case to

0.4 bar. On the other hand, the condenser pressure value is so close to the pressure value of low pressure heater 6 *LPH6* ( $p_{11} = 0.665 \text{ bar}$ ), this will cause a diminishing in the passage of steam to the condenser.

**Table 3: Comparison of the extraction steam flow rate between the design case and the operational case for Alkhoms steam power plant.**

No.	Steam extraction lines	Design case	Operational case
1.	High pressure heater1 ( <i>HPH1</i> )	5.22 kg/s	-
2.	High pressure heater 2 ( <i>HPH2</i> )	4.59 kg/s	-
3.	High pressure heater 3 ( <i>HPH3</i> )	3.057 kg/s	-
4.	Feed water tank ( <i>FWT4</i> )	5.67 kg/s	4.26 kg/s
5.	High pressure heater 5 ( <i>LPH5</i> )	5.74 kg/s	4.60 kg/s
6.	High pressure heater 6 ( <i>LPH6</i> )	8.96 kg/s	1.47 kg/s

Table 4 shows a comparison of the results between the design case and operational case of Alkhoms steam power plant. It can be observed, that the thermal efficiency ( $\eta_{th}$ ) of the power plant decreases in the operational case within 5.43 %, and also the specific work ( $w_{ST}$ ) decreases about 60 kJ/kg

approximately. In addition, the feed water temperature ( $t_w$ ) decreases in the operational case by around 74 °C due to the shut-off of the high pressure heaters (*HPH1*, *HPH2* and *HPH3*) of the power plant, which resulting from the steam leakage in those heaters.

**Table 4: Comparison of the thermodynamic parameters between the design case and the operational case for Alkhoms steam power plant.**

No.	Parameters	Design case	Operational case	Difference
1.	Power output ( $P_{ST}$ )	120 MW	95 MW	- 25 MW
2.	Specific work ( $w_{ST}$ )	1276.24 kJ/kg	1216.04 kJ/kg	- 60.2 kJ/kg
3.	Mass flow rate ( $\dot{m}_{ST}$ )	96.43 kg/s	80.12 kg/s	- 16.31 kg/s
4.	Thermal efficiency ( $\eta_{th}$ )	36.36 %	30.93 %	- 5.43 %
5.	Feed water temperature ( $t_w$ )	226.5 °C	152.5 °C	-74 °C
6.	Condenser pressure ( $p_{Cond.}$ )	0.0538 bar	0.4 bar	+ 0.3462 bar



The results illustrated that the thermodynamic parameters in the operational case led to be different than the design case. The decrease in the thermodynamic parameters of the operational case was due to an increase in the condenser pressure value. The reason for the increase in condenser pressure is a defect in the condenser pipe cleaning system caused by seaweed and sand.

By applying a regular cleaning system to the condenser tubes and repair of serviceable high pressure heaters (*HPH1*, *HPH2* and *HPH3*) in Alkhoms steam turbine power plant, these procedures will lead to: decreasing of the condenser pressure, improving the thermal performance of low pressure heater 6 (*LPH6*), increasing in the temperature of the feed water and decreasing in an annually fuel consumption. Consequently, an improvement in the performance of Alkhoms steam power plant.

In this paper, the thermodynamic performance analysis of Alkhoms steam turbine power plant was performed and the following points were concluded:

- The analyses showed that the thermodynamic parameters decreased for the operational case. Compared with the design case, the specific work and the thermal efficiency of the Alkhoms steam power plant decreased by about 60 kJ/kg and 5.43 % respectively, and also the feed water temperature decreased around 74°C.
- The decrease in the thermodynamic parameters of the operational case is due to a rise in the condenser pressure and also due to the shut-off in the high pressure heaters of the plant.
- Maintenance of the condenser (cleaning the sand and seaweed), and the high pressure heaters (steam leakage) should be carried in order to improve the thermodynamic parameters of the operational condition of Alkhoms steam power plant.

## Nomenclature

$h$	Specific enthalpy ( $kJ/kg$ )		
$\dot{m}$	Mass flow rate ( $kg/s$ )	Cond.	Condenser
$m$	Unit steam extractions	E	Extraction
$P$	Output power ( $MW$ )	f	Fuel
$p$	Pressure (bar)	HP	High pressure
$\dot{Q}$	Heat added ( $kW$ )	HPH	High pressure heater
$T$	Temperature ( $K$ or $^{\circ}C$ )	IP	Intermediate pressure
$w$	specific work ( $kJ/kg$ )	LP	Low pressure
$\eta$	efficiency	LPH	Low pressure heater
		ST	Steam

## Subscripts



## 6. REFERENCES

- [1] W. Li, P. Priddy, Power Plant System Design, John Wiley & Sons, Canada (1985).
- [2] Hesham G. Ibrahim<sup>1</sup>, Aly Y. Okasha, Ahmed G. Elkhalidy, Improve Performance and Efficiency of the Steam Power Plant, First Scientific Conference on Petroleum Resources and Manufacturing, 27-28 October 2010 Brega, Libya.
- [3] Hesham G. Ibrahim, Mokhtar S. Elatrash, Aly Y. Okasha, Steam Power Plant Design Upgrading (Case Study: Khoms Steam Power Plant), Energy and Environment Research, Vol. 1/1, p. 202-211 (2011)
- [4] MuammerAlus, Mohamed Elrawemi, Faraj Eldabee, Thermoeconomic Optimization of Steam Condenser for Combined Cycle Power Plant, International Journal of Science and Engineering Applications, Vol. 6/3, p. 70-75 (2017).
- [5] GECOL, Technical Specification Catalog for Al Khums Steam Power Plant.
- [6] Milan V. Petrovic, Steam Turbines Calculation and Design, Beograd (2009).
- [7] W. Wagner, A. Kruse, Properties of Water and Steam, IAPWS-IF97, Springer, Berlin, (1998).
- [8] W. Li, P. Priddy, Power Plant System Design, John Wiley & Sons, Canada (1985).

